

Maths Revision



Number and Place Value

Use numbers from -1000 to 10 000 000

(The curriculum is not specific about how far to use negative numbers)

Counting

Count forwards and backwards in 4, 6, 7, 8, 9, 25, 50, steps of powers of 10 (10, 100, 1000, ...)

7, 14, 21, 28, 35, 42, ...

625, 600, 575, 550, 525, ...

57 382, 67 382, 77 382, 87 382, ...

Find 10, 100 or 1000 more or less than a given number.

What is 100 less than 1902?

What is 1000 more than 3249?

Count forwards and backwards through zero

6, 5, 4, 3, 2, 1, 0, -1, -2, -3 ...

Negative numbers

Use negative numbers in context and calculate intervals across zero.

The temperature inside is 19°C and outside is -4°C. What is the difference in temperature between inside and outside?

Place Value

Recognise the place value of each digit in up to four-digit numbers.

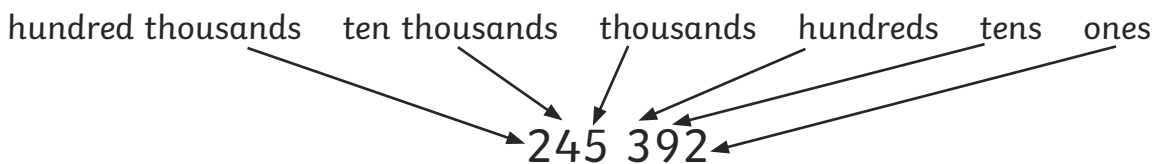

Compare and Order Numbers

Compare using <, > or =

$$141\ 141 < 144\ 114$$

$$501\ 243 > 501\ 234$$

Smallest 11 112 11 211 121 211 122 121 122 211 Greatest

Identify, Represent and Estimate

Use models and representations of numbers.

2850 can be represented by

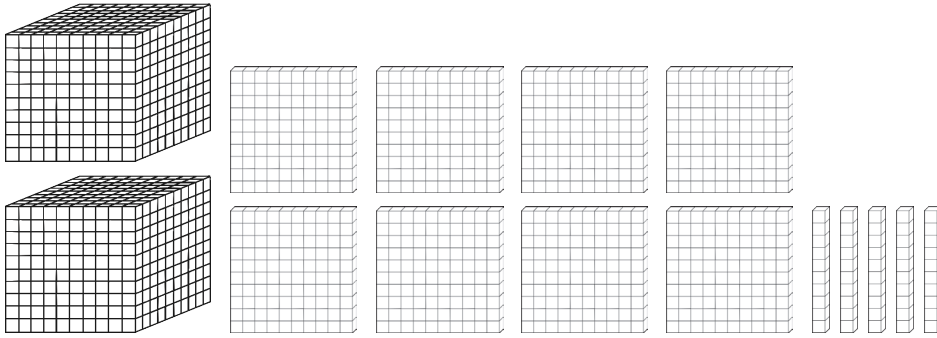

Rounding

Round numbers to the nearest 10, 100, 1000, 10 000 or 100 000 and any whole number.

Remember 5 rounds up.

4500 rounded to the nearest 1000 is 5000 (the 500 rounds up).

253 450 to the nearest 10 000 is 250 000 (the 3450 rounds down).

374 rounded to the nearest 50 is 350 (74 is nearer to 50 than 100).

Read and Write Numbers in Numerals and Words

344 285 is three hundred and forty-four thousand, two hundred and eighty-five.

Roman Numerals

Use the following Roman numerals to represent numbers to 100:

Roman	Numeral
I	1
V	5
X	10
L	50
C	100
D	500
M	1000

CCXIX = 219

DCXXVI = 626

CMXLVIII = 948

MDCCCLXXI = 1871

Solve Problems

Here are 3 years written in Roman Numerals. Order the years from earliest to latest:

MMIX

MCMXCIX

MMXV

MCMCXIX (1999)

MMIX (2009)

MMXV (2015)

Addition and Subtraction

Add and Subtract Mentally

Add and subtract three-digit numbers and ones, tens and hundreds.

$376 + 3 = 379$

$376 + 40 = 416$

$376 + 200 = 576$

Mental Methods

Add and subtract numbers mentally with larger numbers.

$15\ 672 - 3200 = 12\ 472$

Estimate, Round, Levels of Accuracy and Inverse

Estimate by rounding to check accuracy: $54318 + 21298 \approx 54300 + 21300 \approx 75600$

Inverse: check $7932 - 3457 = 4475$, by $3457 + 4475 = 7932$

Multiplication Tables

Multiplication and division facts to 12×12

x	1	2	3	4	5	6	7	8	9	10	11	12
1	1	2	3	4	5	6	7	8	9	10	11	12
2	2	4	6	8	10	12	14	16	18	20	22	24
3	3	6	9	12	15	18	21	24	27	30	33	36
4	4	8	12	16	20	24	28	32	36	40	44	48
5	5	10	15	20	25	30	35	40	45	50	55	60
6	6	12	18	24	30	36	42	48	54	60	66	72
7	7	14	21	28	35	42	49	56	63	70	77	84
8	8	16	24	32	40	48	56	64	72	80	88	96
9	9	18	27	36	45	54	63	72	81	90	99	108
10	10	20	30	40	50	60	70	80	90	100	110	120
11	11	22	33	44	55	66	77	88	99	110	121	132
12	12	24	36	48	60	72	84	96	108	120	132	144

Multiplying and Dividing

Use place value and known facts: $400 \times 5 = 2000$, $630 \div 7 = 90$

Multiply by 0 and 1 and divide by 1: $285 \times 1 = 285$, $285 \times 0 = 0$, $285 \div 1 = 285$

Multiplying and dividing whole numbers and decimals by 10, 100 and 1000:

When multiplying or dividing a number by 10, 100 or 1000, keep the digits in the number together. When multiplying the number gets larger and when dividing the number gets smaller. The numbers will move in place value by the number of 0's.

$$45 \times 10 = 450$$

$$6.7 \times 100 = 670$$

$$902 \times 1000 = 902\,000$$

$$59 \div 10 = 5.9$$

$$4506 \div 100 = 45.06$$

$$382 \div 1000 = 0.382$$

Common Multiples, Factor Pairs, Common Factors and Commutativity

12 is a common multiple of 4 and 6, because 12 is a multiple of 4 and a multiple of 6.

All the factor pairs of 56 are 1 and 56, 2 and 28, 4 and 14, 8 and 7.

Use this to solve: 56 pencils are shared between 4 tables. How many pencils does each table receive?

The common factors of 32 and 56 are 1, 2, 4 and 8 because they are factors of both 32 and 56.

Commutativity means changing the order of the numbers in a calculation does not change the answer: $5 \times 9 \times 2 = 5 \times 2 \times 9 = 10 \times 9 = 90$

Prime Numbers

Prime numbers only have 1 and itself as factors.

Prime factors are factors of a number that are prime numbers:

the prime factors of 21 are 3 and 7, the prime factors of 24 are 2 and 3.

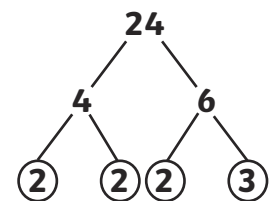

Composite numbers are non-prime numbers: 4 is a composite number because 2 is a factor.

Recall the prime numbers to 19: 2, 3, 5, 7, 11, 13, 17 and 19

Square and Cube Numbers

The square numbers are 1, 4, 9, 16, 25, 36, 49, 64, 81, 100, 121, 144, 169, 196, 225,...

$$\text{e.g. } 3^2 = 3 \times 3 = 9$$

$$7^2 = 7 \times 7 = 49$$

The cube numbers are 1, 8, 27, 64, 125,...

$$\text{e.g. } 2^3 = 2 \times 2 \times 2 = 8$$

$$5^3 = 5 \times 5 \times 5 = 125$$

Order of Operations

BODMAS is a way of remembering the order in which operations are carried out.

Brackets first: $3 \times (4 + 5) = 3 \times 9 = 27$

Order - square or cube: $4 + 3^2 = 4 + 9 = 13$

Division and Multiplication: $4 + 3 \times 2 = 4 + 6 = 10$

Addition and Subtraction: (as in examples above)

Division and multiplication are carried out in the order they are in the expression.

Addition and subtraction are carried out in the order they are in the expression.

Formal Methods

72 698 + 61 562 becomes

$$\begin{array}{r} 72698 \\ + 61562 \\ \hline 134260 \\ \text{1 1 1} \end{array}$$

Answer: 13 4260

84 935 - 12 423 becomes

$$\begin{array}{r} 84935 \\ - 12423 \\ \hline 72512 \end{array}$$

Answer: 72 512

64 812 - 29 364 becomes

$$\begin{array}{r} \overset{5}{\cancel{6}} \overset{1}{4} \overset{7}{\cancel{8}} \overset{10}{\cancel{1}} \overset{1}{2} \\ - 29364 \\ \hline 35448 \end{array}$$

Answer: 35 448

Use formal methods to multiply up to 4 digit numbers by 1 digit numbers.

27 × 4 becomes

$$\begin{array}{r} 27 \\ \times 4 \\ \hline 108 \\ \text{2} \end{array}$$

Answer: 108

382 × 7 becomes

$$\begin{array}{r} 382 \\ \times 7 \\ \hline 2674 \\ \text{5 1} \end{array}$$

Answer: 2394

2471 × 6 becomes

$$\begin{array}{r} 2471 \\ \times 6 \\ \hline 14826 \\ \text{2 4} \end{array}$$

Answer: 14 826

Use the formal long multiplication method for multiplying 2 digit numbers by 2 digit numbers.

27 × 14 becomes

$$\begin{array}{r} \overset{2}{2} 7 \\ \times 14 \\ \hline 108 \\ 270 \\ \hline 378 \end{array}$$

Answer: 378

147 × 23 becomes

$$\begin{array}{r} \overset{1}{1} \overset{1}{4} 7 \\ \times 23 \\ \hline 441 \\ 2940 \\ \hline 3381 \\ \text{1} \end{array}$$

Answer: 378

Use short division for up to 4 digit numbers divided by one-digit numbers.

$74 \div 4$ becomes

$$\begin{array}{r} 19 \\ 4 \overline{) 736} \end{array}$$

Answer: 19

$487 \div 5$ becomes

$$\begin{array}{r} 97 \text{ r } 2 \\ 5 \overline{) 4837} \end{array}$$

Answer: 97 r 2

Use long division for up to 4 digit numbers divided by two-digit numbers.

Express remainders as whole numbers, fractions or decimals.

$516 \div 15$ becomes

$$\begin{array}{r} 34 \text{ r } 6 \\ 15 \overline{) 516} \\ \underline{450} \\ 66 \\ \underline{60} \\ 6 \end{array}$$

Answer: 34 r 6

$516 \div 15$ becomes

$$\begin{array}{r} 34 \\ 15 \overline{) 516} \\ \underline{450} \quad 15 \times 30 \\ 66 \\ \underline{60} \quad 15 \times 4 \\ 6 \end{array}$$

$$\frac{6}{15} = \frac{2}{5}$$

Answer: $34\frac{2}{5}$

$516 \div 15$ becomes

$$\begin{array}{r} 34.4 \\ 15 \overline{) 516.0} \\ \underline{450} \quad \downarrow \\ 66 \\ \underline{60} \quad \downarrow \\ 60 \\ \underline{60} \quad \downarrow \\ 0 \end{array}$$

Answer: 34.4

Solve Problems

Multi-step problems

8451 people visit a cinema on one day. There are two films showing. 3549 adults and 946 children see an adventure film, 1263 adults and a number of children see an animation. How many more children see the animation than the adventure film?

$$3549 + 1263 = 4812 \text{ adults}$$

$$8451 - 4812 = 3639 \text{ children}$$

$$3639 - 946 = 2693 \text{ children see the animation}$$

$$2693 - 946 = 1747 \text{ more children see the animation than the adventure film}$$

Using knowledge of factors, prime numbers, square and cube numbers, explain why the numbers 1 to 10 are placed in this Venn Diagram in this way.

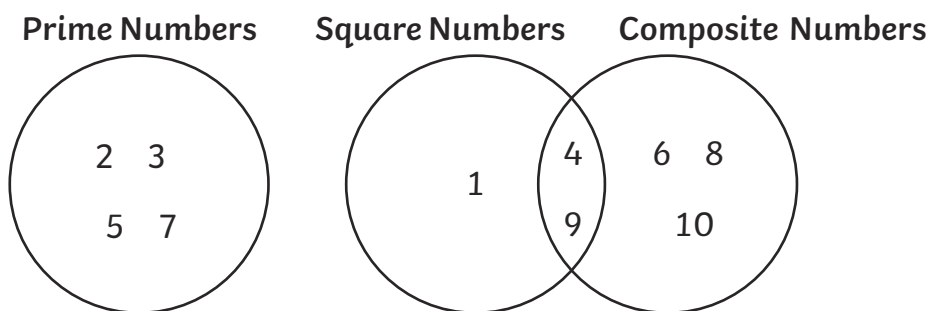

Missing number problems: $\square \times 3 = 45$ or $56 \div \square = 14$

Word Problems

A teacher has four new boxes of pencils, each with 12 pencils, and a tray with 37 pencils. The teacher shares equally all the pencils between 5 tables. How many pencils does each table receive?

$$12 \times 4 = 48 \text{ new pencils}$$

$$48 + 37 = 85 \text{ pencils}$$

$$85 \div 5 = 17 \text{ pencils per table}$$

Scaling Problems with Simple Fractions

12 pizzas are cut into quarters. How many quarters of pizza will there be altogether?

Correspondence Problems

Jenna has 2 t-shirts and 4 pairs of shorts. How many different combinations of the t-shirts and shorts does Jenna have?

120 pencils are shared equally between 3 classes. How many pencils will they each receive?

Using the Distributive Law $39 \times 7 = 30 \times 7 + 9 \times 7 = 210 + 63 = 273$

Fractions

Tenths

Counting: $\frac{7}{10}, \frac{6}{10}, \frac{5}{10}, \frac{4}{10}, \dots$

Dividing into 10 equal parts or by 10

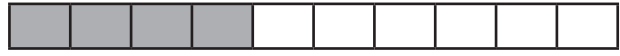

Counting: $\frac{47}{100}, \frac{46}{100}, \frac{45}{100}, \frac{44}{100}, \dots$

Dividing into 100 equal parts or by 100 or tenths by 10

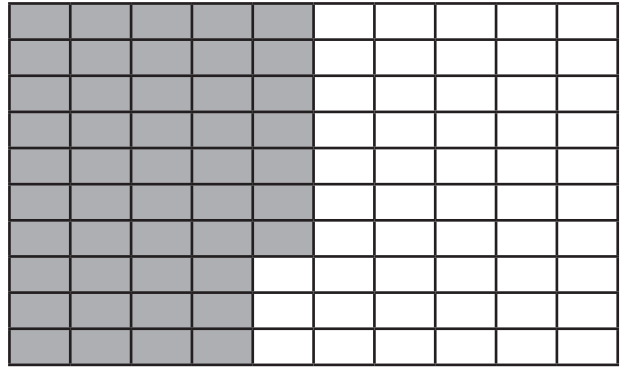

There are 10 thousandths in one hundredth and 100 thousandths in one tenth.

Fraction of a Set of Marbles

Find $\frac{5}{8}$ of these marbles

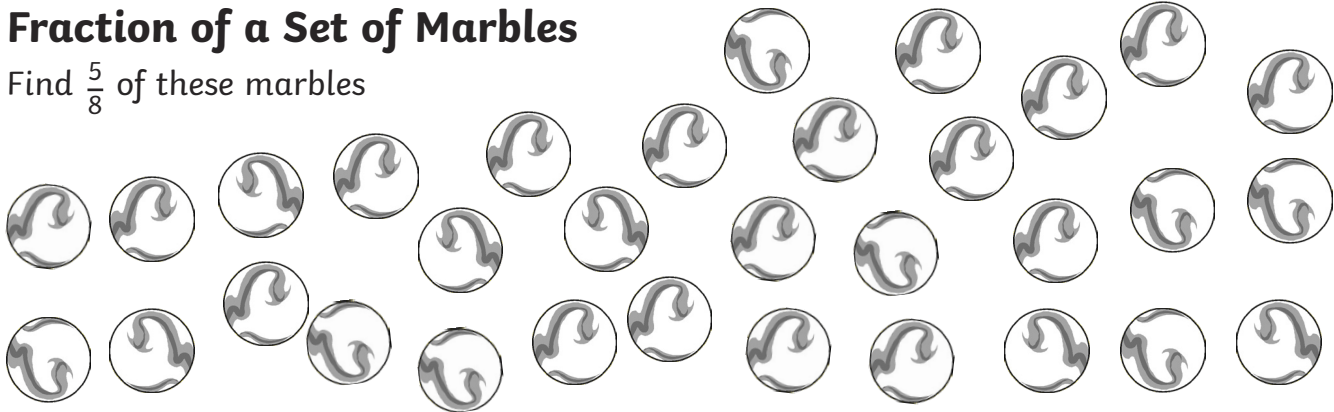

$$32 \div 8 = 4$$

$$4 \times 5 = 20$$

Equivalent Fractions



$$\frac{3}{4}$$

=



$$\frac{6}{8}$$

=



$$\frac{12}{16}$$

1															
$\frac{1}{2}$								$\frac{1}{2}$							
$\frac{1}{4}$				$\frac{1}{4}$				$\frac{1}{4}$				$\frac{1}{4}$			
$\frac{1}{8}$	$\frac{1}{8}$	$\frac{1}{8}$	$\frac{1}{8}$	$\frac{1}{8}$	$\frac{1}{8}$	$\frac{1}{8}$	$\frac{1}{8}$	$\frac{1}{8}$	$\frac{1}{8}$	$\frac{1}{8}$	$\frac{1}{8}$	$\frac{1}{8}$	$\frac{1}{8}$	$\frac{1}{8}$	$\frac{1}{8}$

1																							
$\frac{1}{3}$								$\frac{1}{3}$								$\frac{1}{3}$							
$\frac{1}{6}$				$\frac{1}{6}$				$\frac{1}{6}$				$\frac{1}{6}$				$\frac{1}{6}$				$\frac{1}{6}$			
$\frac{1}{12}$	$\frac{1}{12}$	$\frac{1}{12}$	$\frac{1}{12}$	$\frac{1}{12}$	$\frac{1}{12}$	$\frac{1}{12}$	$\frac{1}{12}$	$\frac{1}{12}$	$\frac{1}{12}$	$\frac{1}{12}$	$\frac{1}{12}$	$\frac{1}{12}$	$\frac{1}{12}$	$\frac{1}{12}$	$\frac{1}{12}$	$\frac{1}{12}$	$\frac{1}{12}$	$\frac{1}{12}$	$\frac{1}{12}$	$\frac{1}{12}$	$\frac{1}{12}$	$\frac{1}{12}$	
$\frac{1}{24}$	$\frac{1}{24}$	$\frac{1}{24}$	$\frac{1}{24}$	$\frac{1}{24}$	$\frac{1}{24}$	$\frac{1}{24}$	$\frac{1}{24}$	$\frac{1}{24}$	$\frac{1}{24}$	$\frac{1}{24}$	$\frac{1}{24}$	$\frac{1}{24}$	$\frac{1}{24}$	$\frac{1}{24}$	$\frac{1}{24}$	$\frac{1}{24}$	$\frac{1}{24}$	$\frac{1}{24}$	$\frac{1}{24}$	$\frac{1}{24}$	$\frac{1}{24}$	$\frac{1}{24}$	$\frac{1}{24}$

1																			
$\frac{1}{5}$					$\frac{1}{5}$					$\frac{1}{5}$					$\frac{1}{5}$				
$\frac{1}{10}$		$\frac{1}{10}$		$\frac{1}{10}$		$\frac{1}{10}$		$\frac{1}{10}$		$\frac{1}{10}$		$\frac{1}{10}$		$\frac{1}{10}$		$\frac{1}{10}$		$\frac{1}{10}$	
$\frac{1}{20}$	$\frac{1}{20}$	$\frac{1}{20}$	$\frac{1}{20}$	$\frac{1}{20}$	$\frac{1}{20}$	$\frac{1}{20}$	$\frac{1}{20}$	$\frac{1}{20}$	$\frac{1}{20}$	$\frac{1}{20}$	$\frac{1}{20}$	$\frac{1}{20}$	$\frac{1}{20}$	$\frac{1}{20}$	$\frac{1}{20}$	$\frac{1}{20}$	$\frac{1}{20}$	$\frac{1}{20}$	$\frac{1}{20}$

Write 4 fractions that are equivalent to $\frac{3}{4}$ $\frac{6}{9}$ $\frac{9}{12}$ $\frac{12}{16}$ $\frac{15}{20}$

Use common factors to simplify fractions

$\frac{9}{15} = \frac{3}{5}$ 9 and 15 have 3 as a common factor

Expressing Fractions with the Same Denominator

Use common multiples

$\frac{4}{5}$ and $\frac{3}{8}$

40 is the smallest common multiple of 5 and 8

$\frac{4}{5}$ becomes $\frac{32}{40}$ $\frac{3}{8}$ becomes $\frac{15}{40}$

Mixed Numbers and Improper Fractions

Mixed fraction (whole number and fraction) $1\frac{2}{3} = \frac{5}{3}$ Improper fraction (numerator is larger than the denominator)

Add and Subtract Fractions with the Same Denominator and with Denominators that are Multiples, and with Different Denominators and Mixed Numbers

Add or subtract the numerator, keeping the denominator the same. The answer can be expressed as an equivalent fraction.

$$\frac{1}{8} + \frac{3}{8} = \frac{4}{8} = \frac{1}{2}$$



$$\frac{5}{8} - \frac{3}{8} = \frac{2}{8} = \frac{1}{4}$$

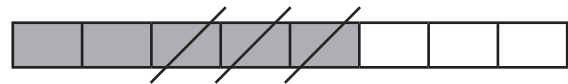

If the denominators are different, convert the fractions to equivalent fractions with the same denominator before adding or subtracting.

$$\frac{1}{4} + \frac{3}{8} = \frac{2}{8} + \frac{3}{8} = \frac{5}{8}$$

$$\frac{4}{5} + \frac{3}{8} = \frac{32}{40} + \frac{15}{40} = \frac{47}{40} = 1\frac{7}{40}$$

Compare and Order

Unit fractions smallest $\frac{1}{8}$ $\frac{1}{6}$ $\frac{1}{4}$ $\frac{1}{3}$ greatest

Fractions with the same denominator $\frac{1}{5} < \frac{3}{5}$

Fractions with denominators that are multiples $\frac{5}{8} > \frac{1}{4}$

Multiply Fractions

Multiply proper fractions and mixed numbers by whole numbers.

Proper fractions - multiply the numerator by the whole number: $\frac{2}{3} \times 5 = \frac{10}{3} = 3\frac{1}{3}$

Mixed numbers – multiply the whole numbers and add the product of the fraction and whole number: $2\frac{2}{3} \times 3 = 6 + \frac{6}{3} = 6 + 2 = 8$

Divide Fractions

Divide proper fractions by whole numbers – multiply the denominator by the whole number:

$$\frac{1}{4} \div 2 = \frac{1}{8}$$

Decimal Equivalents

Tenths and hundredths:

$$\frac{7}{10} = 0.7$$

$$\frac{43}{100} = 0.43$$

$$\frac{1}{4} = 0.25$$

$$\frac{1}{2} = 0.5$$

$$\frac{3}{4} = 0.75$$

Write decimals as a fraction: $0.67 = \frac{67}{100}$

Calculate decimal fraction equivalents: $\frac{3}{8} = 0.375$ because $3 \div 8 = 0.375$

Decimal Place Value

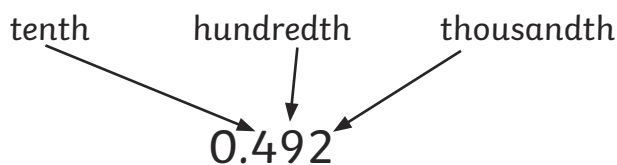

Multiplication and Division

By 10, 100 and 1000:

$$0.2 \times 10 = 2 \quad 2 \div 100 = 0.02 \quad 0.25 \times 100 = 25 \quad 25 \div 1000 = 0.025$$

Multiply one-digit numbers up to 2 decimal places by whole numbers.

$$0.04 \times 7 = 0.28 \quad 0.2 \times 45 = 9$$

Rounding Decimals

To the nearest whole number:

0.5 rounds to 1 because the 5 rounds up

2.35 rounds to 2 because the 3 rounds down (ignoring the 5)

To one decimal place:

0.05 rounds to 0.1 because the 5 rounds up.

Read, Write, Order and Compare Decimals

0.45 is zero point four five (not zero point forty-five)

$$0.45 < 0.5$$

$$0.561 > 0.516$$

Percentages

% means out of 100

$$50\% = \frac{50}{100} = \frac{1}{2} \quad 41\% = \frac{41}{100}$$

Solve Problems

Fractions

Adil divides his marbles into tenths. He wants to give two friends a number of the tenths of his marbles and keep the rest himself. Write 3 ways that he could share the marbles.

$$\text{eg. } \frac{4}{10} + \frac{1}{10} + \frac{5}{10}$$

Measure and Money Problems

Ellie buys a new shirt for £4.75 and a pair of trousers for £3.50 in a sale. She pays with a £10 note. What change will she receive?

A bag of potatoes weigh 2.45kg. How much will 4 bags weigh?

Decimal Problems to 3 Decimal Places

A packet of sugar weighs 1.348kg. $\frac{3}{4}$ kg is used to bake some cakes.
How much will the packet weigh now?

$$1.348\text{kg} - 0.75\text{kg} = 0.598\text{kg}$$

Knowing Percentage and Decimal Equivalents of $\frac{1}{2}$, $\frac{1}{4}$, $\frac{1}{5}$, $\frac{2}{5}$, $\frac{4}{5}$, $\frac{*}{10}$, $\frac{*}{25}$

Order the following from smallest to largest:

$$25\%, \frac{2}{5}, 0.3$$

Ratio and Proportion

Use Multiplication and Division Facts

4 children share 6 pizzas. If 2 more children join the group and each child is to have the same amount of pizza, how many more pizzas are needed?

3 more pizzas

Percentages

Which is greater? 15% of 2 litres 50% of 500ml

Scaled Shapes

The length and width of rectangle A are increased by a scale factor of 3 to make rectangle B. What are the new dimensions of rectangle B?

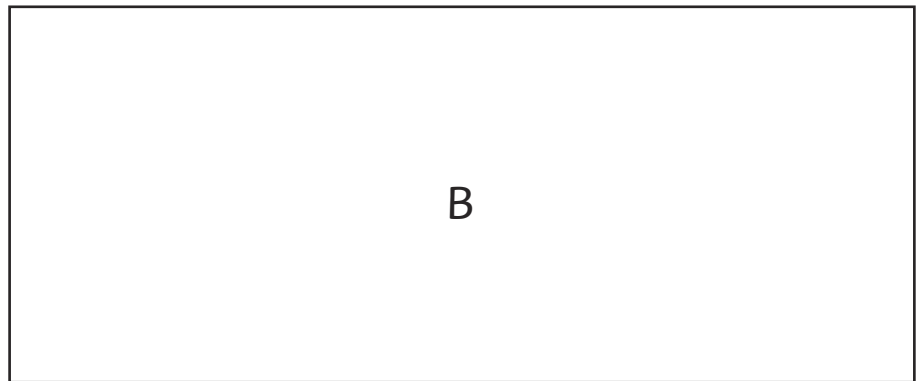
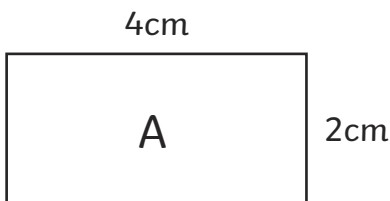

Use Fractions and Multiples

A child has read 50 pages of a book and has $\frac{3}{5}$ to read. How many pages are there left to read?

$\frac{2}{5}$ of the book has been read which is 50 pages

$\frac{1}{5}$ of the book is 25 pages

$\frac{3}{5}$ of the book is 75 pages. There are 75 pages left to read.

Algebra

Formulae

$2s + 4 = t$, if $s = 5$, what is t ? $t = 5 \times 2 + 4 = 14$

Formulae are used in mathematics and science:

Area of a rectangle: $a = lw$

(a = area, l = length and w = width)

Perimeter of a rectangle: $p = 2(l + w)$

(p = perimeter)

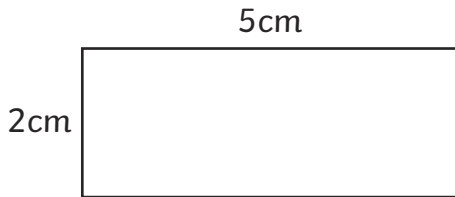

What is the area and perimeter of this rectangle?

Express missing number problems algebraically.

A number (g) is 12 more than a number (h) so $g = h + 12$ or $h = g - 12$

A locksmith charges £15 callout and £20 per hour for any work. What formulae would calculate his charge for h number of hours? $20h + 15$

Sequences

Linear number sequences: 3, 7, 11, 15...

The sequence starts with 3 and each step is 4

so the 1st term is $4 \times 1 - 1 = 3$, the 2nd term is $4 \times 2 - 1 = 7$, the 3rd is $4 \times 3 - 1 = 11...$

therefore the n th term is $4n - 1$

Equations

Find possible pairs of numbers for a and b in $3a + b = 12$.

Some possible answers: $a = 1, b = 9$; $a = 2, b = 6$; $a = 3, b = 3$

Variables

The total of two numbers is 15. Both numbers are between 5 and 10. Find all the possible combinations.

$6 + 9 = 15, 7 + 8 = 15$

Measurement

Estimate, Measure, Compare, Add and Subtract

In all cases, be able to estimate with some accuracy prior to measuring.

Lengths (mm/cm/m)

Measure and draw lines using a ruler in centimetres (cm) or millimetres (mm).

This line is 9.5cm or 95mm long.

Mass (g/kg)

Measure the mass of objects using different scales.

3 apples weigh 435g. One is eaten, and the 2 remaining apples weigh 285g. What is the mass of the eaten apple?

$$435\text{g} - 285\text{g} = 150\text{g}$$

Capacity (ml/l)

Which jug has more water?

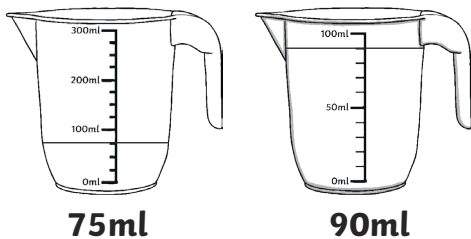

Convert between units

Length: 1 km = 1000m, 1m = 100cm or 1000mm. 1cm = 10mm

Mass: 1kg = 1000g

Capacity/ Volume: 1l = 1000ml

Time: 1 year = 365 days (leap year 366 days), 1 week = 7 days,

30 days hath September,
April, June and November.

All the rest have 31,
Excepting February alone
Which only has but 28 days clear
And 29 in each leap year.

1 day = 24 hours, 1 hour = 60 minutes, 1 minute = 60 seconds

Convert between metric and imperial units

1 inch \approx 2.5cm 5 miles \approx 8 km 1kg \approx 2.2lb (pounds) 1 litre \approx 1.75 pints

A road sign says Sheffield 45 miles. How many kilometres is it to Sheffield? **72km**

Perimeter, Area and Volume

The perimeter is the measurement around the edge of a shape.



The sides of this rectangle are 8cm and 3cm, so the perimeter is 22cm.

Measure and calculate the perimeter of rectilinear shapes (including squares).

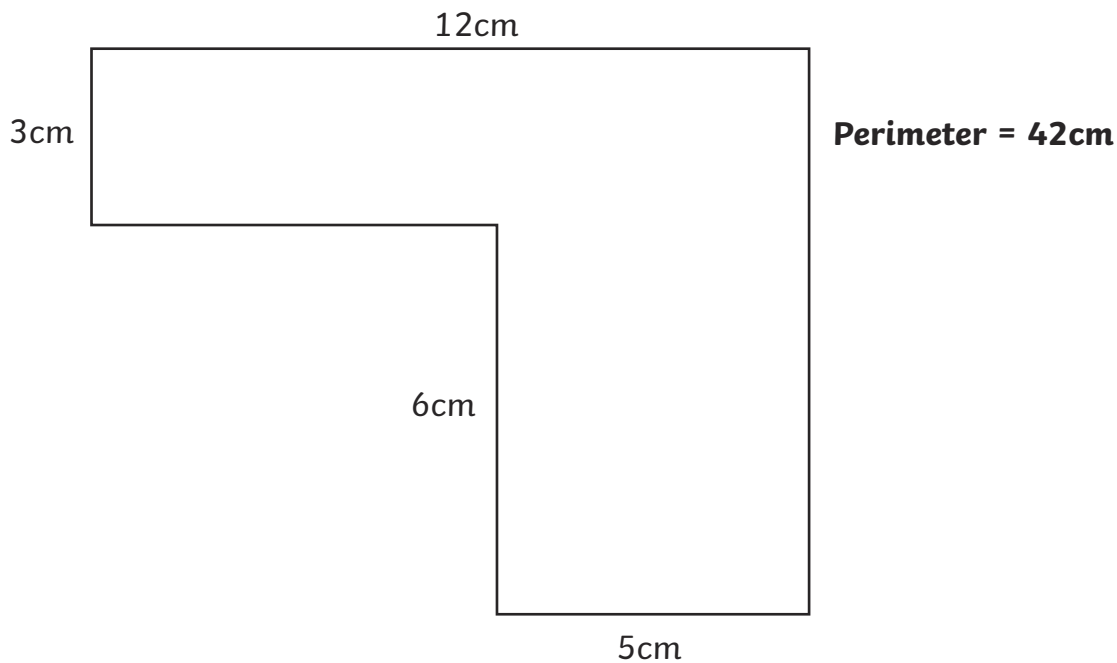

Area

Area of rectilinear shapes by counting squares

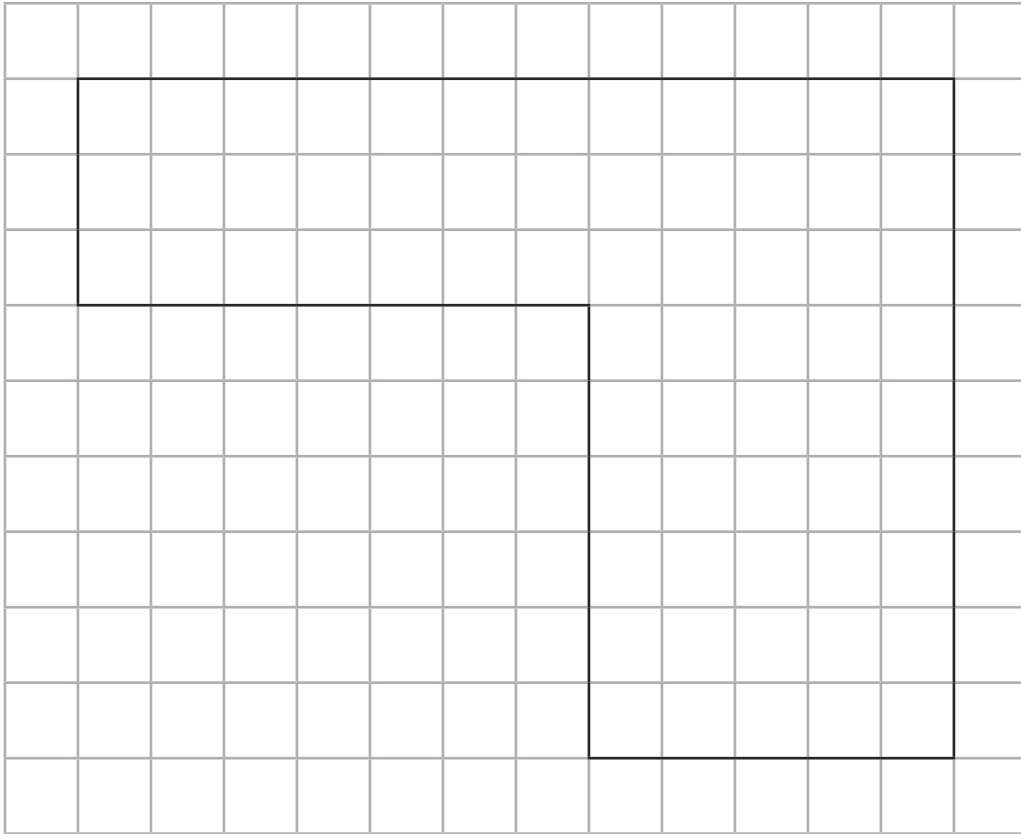

Area = 66cm^2

Calculate the area of rectangles: multiply the length of two adjacent sides.



$\text{Area} = 8\text{cm} \times 3\text{cm} = 24\text{cm}^2$

Estimate the area of irregular shapes:

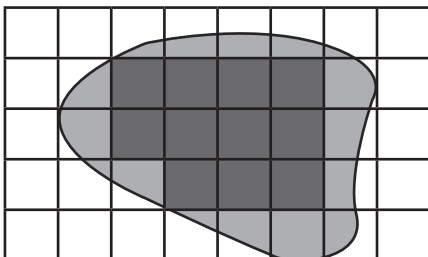

Count the whole squares and the squares with more than half included in the shape.

Shapes with the same area can have different perimeters.

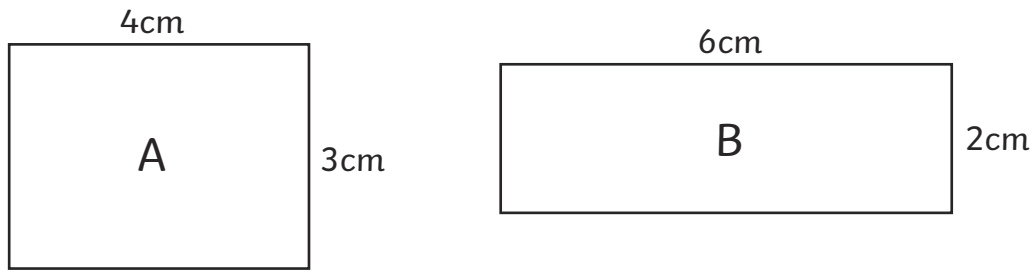

Find the area and perimeter of these rectangles. What do you notice?

The area of both is 12cm^2 , but the perimeter of A is 14cm and B is 16cm, so they are different.

The area of a triangle is based on it being half of a rectangle that includes the triangle.

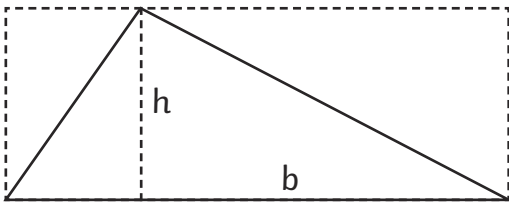

The area of a triangle is half of the base (b) \times the height (h) or $\frac{1}{2}bh$

A similar idea is used to find the area of a parallelogram. Cut a triangle off one end and move to the other and the parallelogram becomes a rectangle.

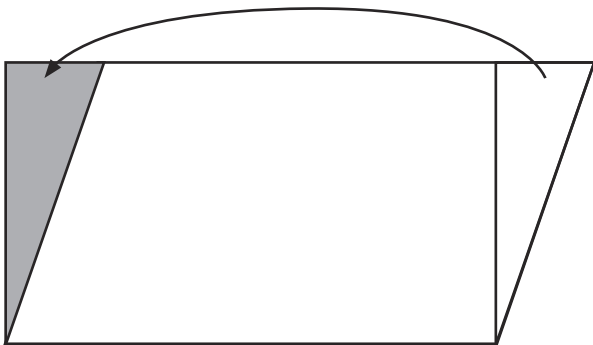

The area of a parallelogram is the base (b) \times the height (h) or bh .

Money

Add and subtract giving change.

Jude buys an apple and an orange costing 25p and 15p. How much change from 50p?

Time

Analogue clocks and 12/24 hour time.

These clocks show quarter to nine:

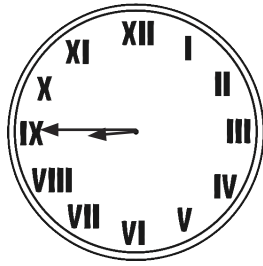
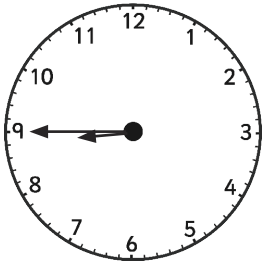

Record time in hours, minutes and seconds.

The maths lesson lasted 1 hour and 5 minutes. The art lesson was one hour and twenty minutes. The art lesson was longer than the maths lesson.

Morning is am, afternoon is pm

A film lasts 136 minutes. How long is the film in hours and minutes?

2 hours and 16 minutes

Solve Problems

2 equal bottles of water contain 500ml of drink. How many litres will 7 bottles hold?

2 bottles hold 500ml, 1 bottle will hold 250ml = 0.25l

7 bottles will hold $0.25l \times 7 = 1.75l$

A 6.5kg bag of soil is divided into 20 pots equally. Each pot needs 0.5kg. How much more does each pot need?

$6.5 \div 20 = 0.325$

$0.5 - 0.325 = 0.175\text{kg}$ is needed by each pot

Geometry – Shape

2D Shapes

Main shapes: circle, triangle, quadrilateral, square, rectangle, rhombus, parallelogram, pentagon, hexagon, octagon, decagon

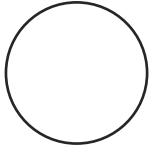

circle

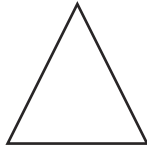

triangle

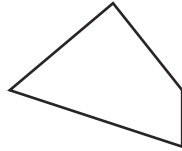

quadrilateral



square

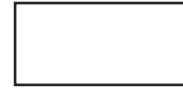

rectangle

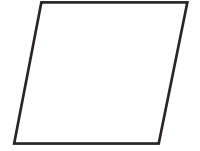

rhombus



parallelogram

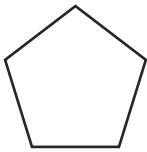

pentagon

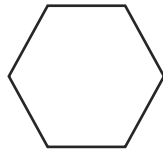

hexagon

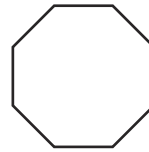

octagon

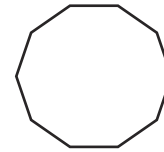

decagon

Draw 2D shapes using given dimensions and angles.

Draw a square with sides 5cm.

Draw an isosceles triangle with one side of 5cm and 2 sides of 7cm.

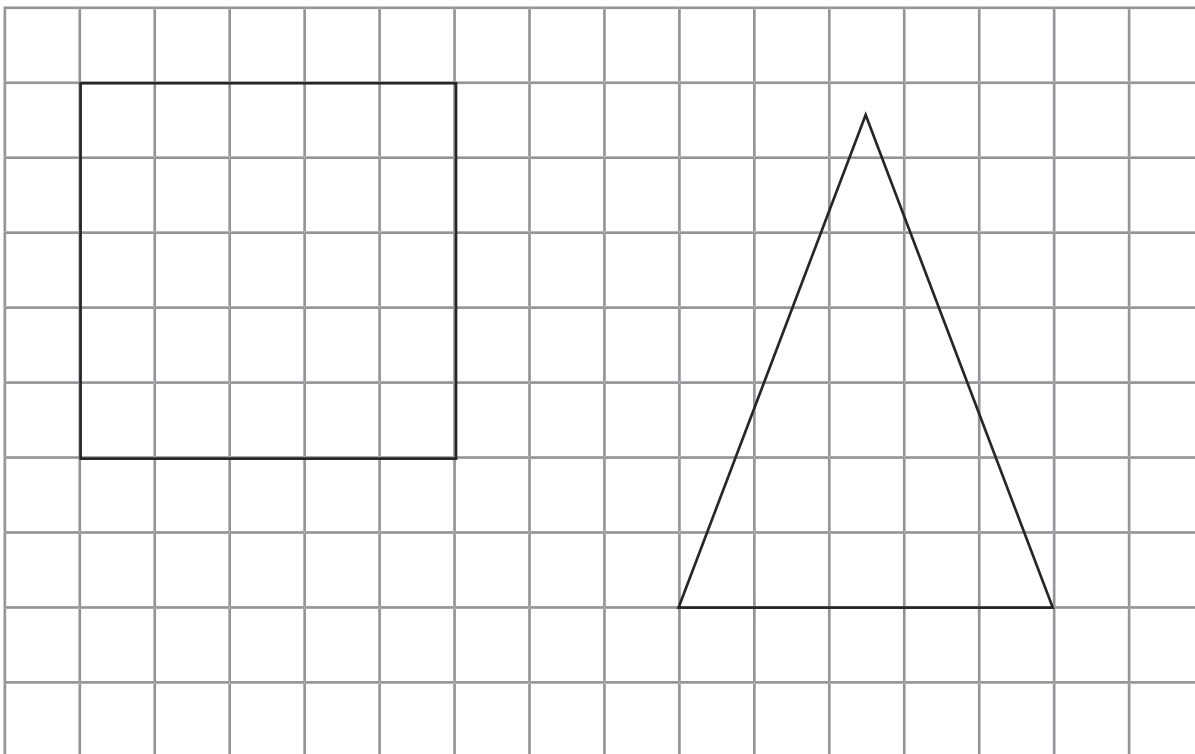

Compare and classify shapes:

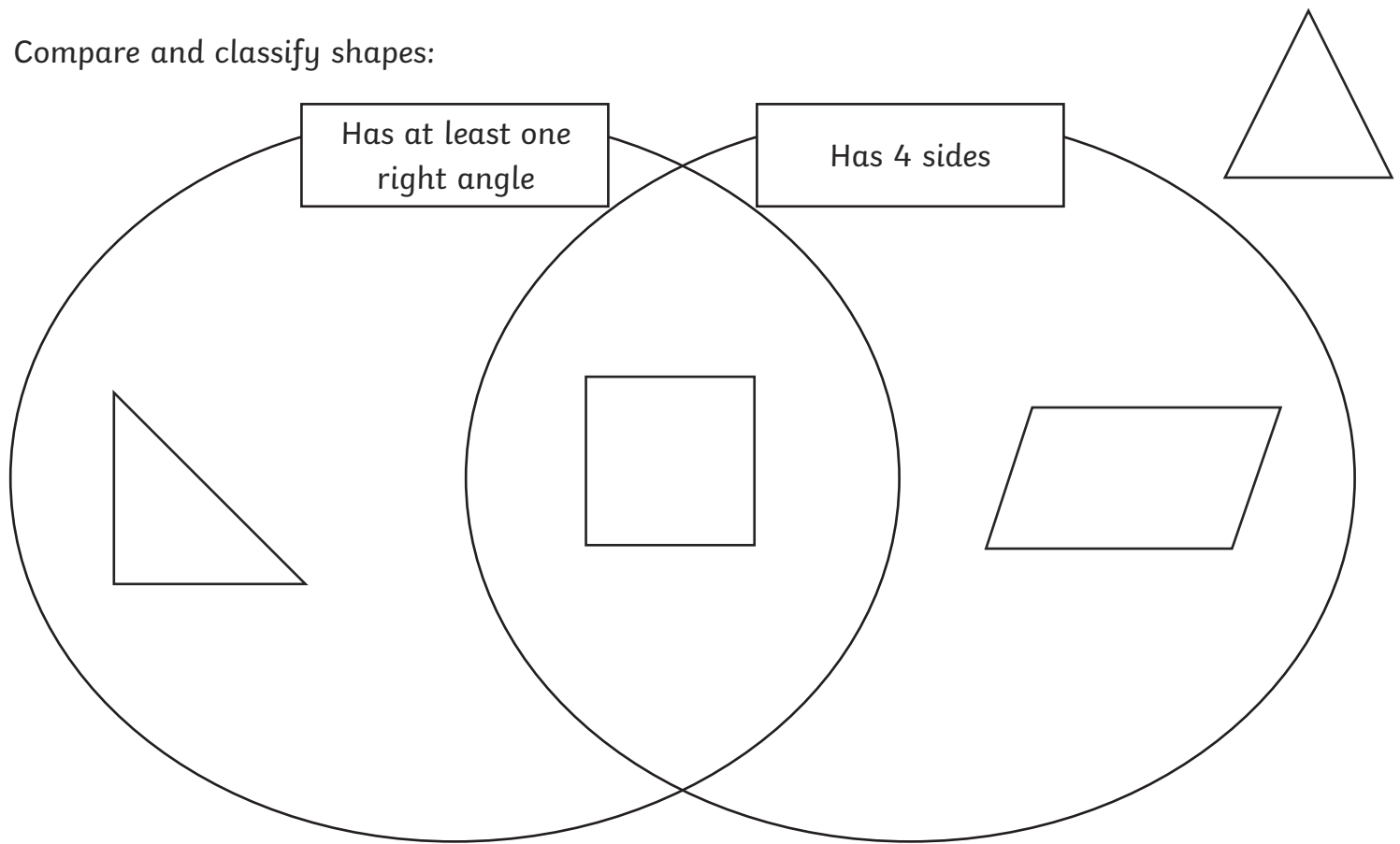

The 4 shapes are classified in this Venn diagram.

Triangles

Equilateral (all sides and angles equal)

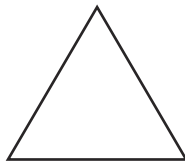

Isosceles (2 sides and angles equal)

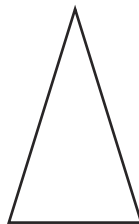

Scalene (no sides and angles equal)

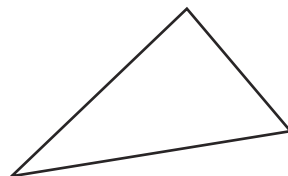

Right-angled triangle (one angle a right angle)

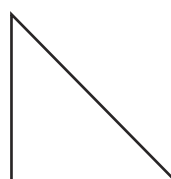

3D Shapes

Main shapes: sphere, cylinder, cube, cuboid, tetrahedron, square-based pyramid, triangular prism, pentagonal prism, hexagonal prism

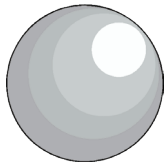

sphere

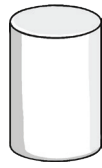

cylinder

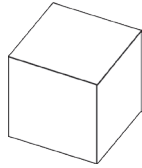

cube

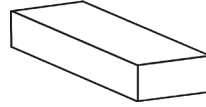

cuboid

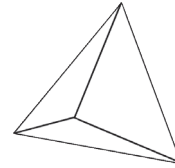

tetrahedron

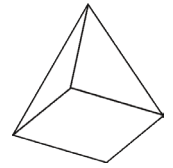

square-based
pyramid

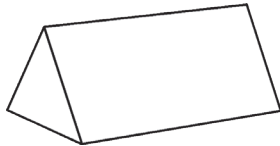

triangular prism

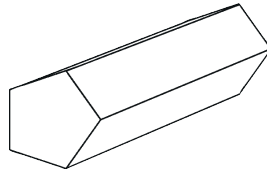

pentagonal prism

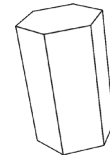

hexagonal prism

Recognise, describe and build simple 3D shapes, including making nets.

What shape is made from this net?

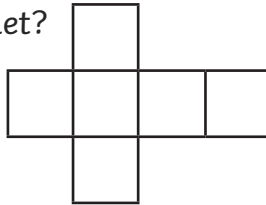

Angles

An angle measures a turn

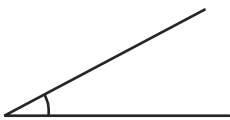

An acute angle is less than a right angle (90°)

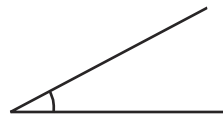

A right angle is the corner of a square

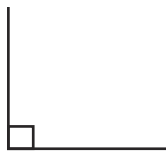

An obtuse angle is between a right angle and a straight line



2 right angles make a straight line

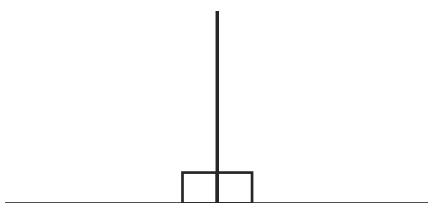

Draw and Measure Angles

One of the lines must be on the 0.

Read the scale on the other line round from 0.

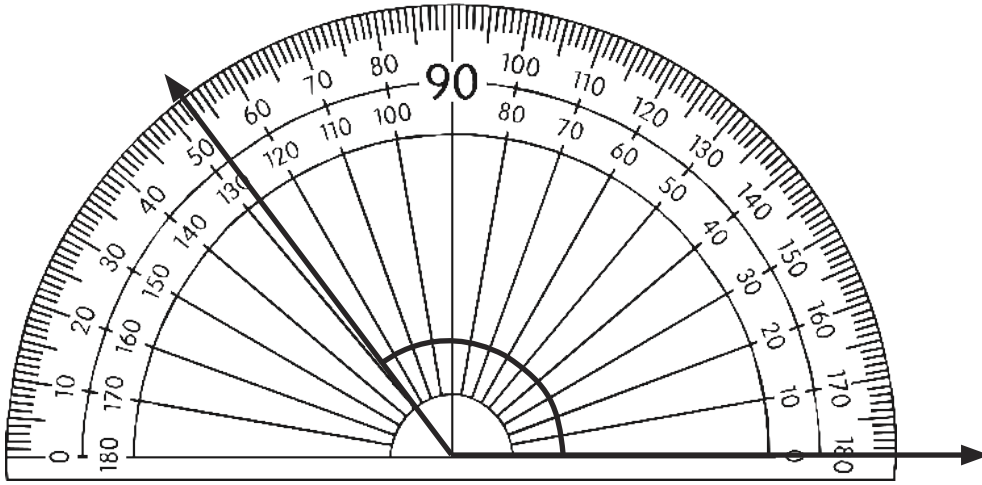

The answer is 127°

The angles at a point and whole turn total 360° (four right angles).

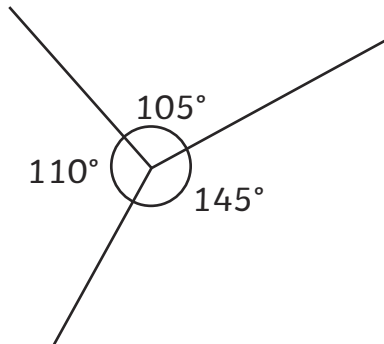

Angles at a point on a line total 180° .

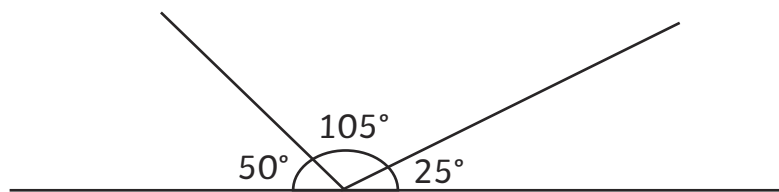

One right angle = 90°

Two right angles = 180°

Three right angles = 270°

Angles in a triangle add up to 180° .

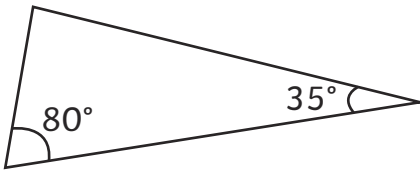

What is the unknown angle?

Angles in a quadrilateral add up to 360° .

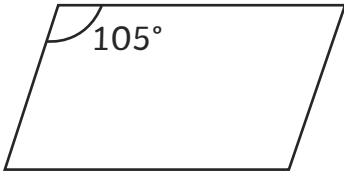

What are the unknown angles in this parallelogram?

Lines

Horizontal 

Vertical 

Parallel Lines 

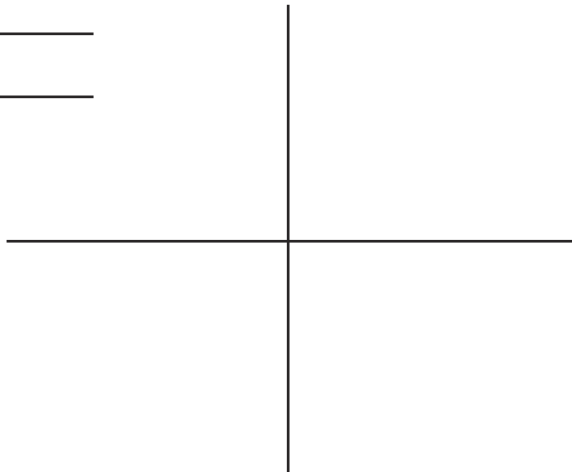
Perpendicular lines (at a right angle) 

Symmetry

Identify lines of symmetry:

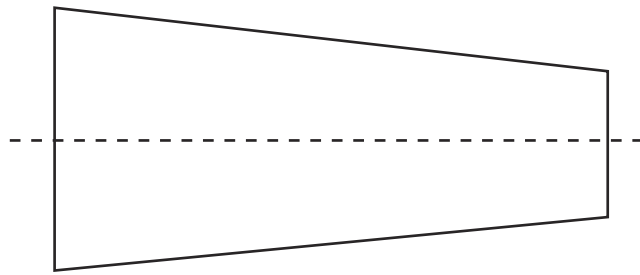
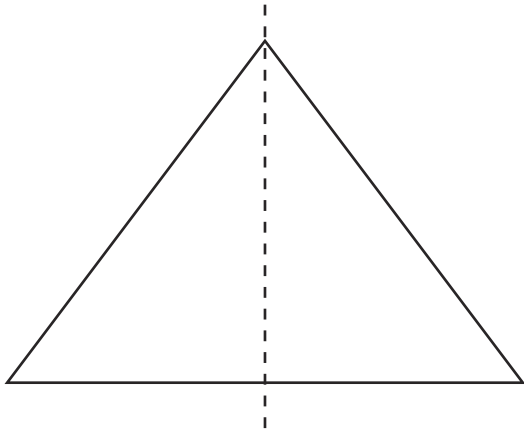

Complete a symmetrical figure:

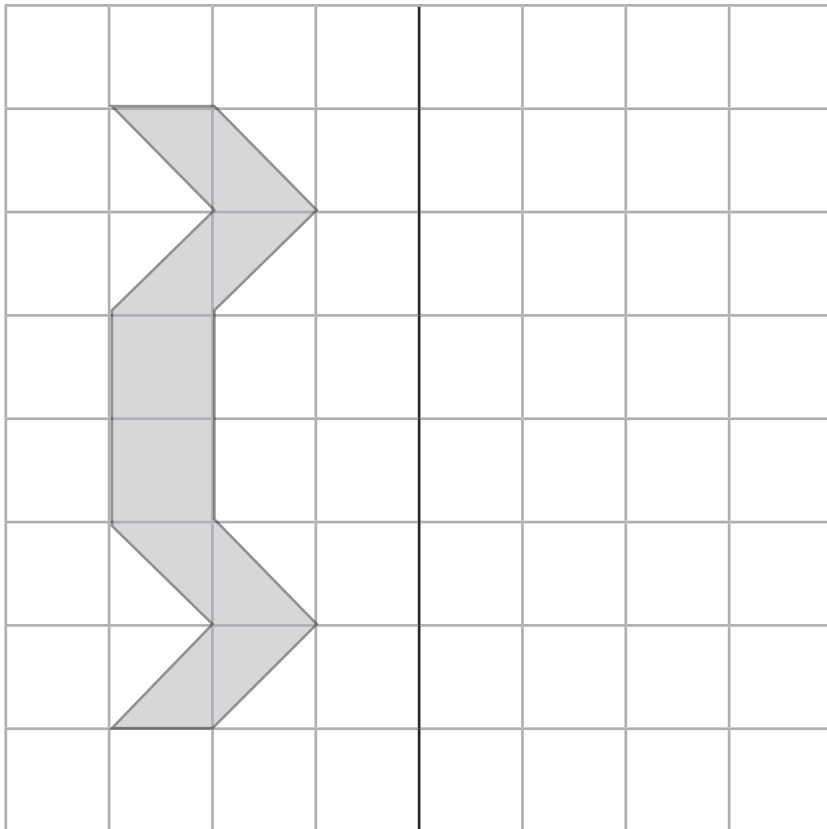

Regular and Irregular Polygons

Regular polygons have equal sides and equal angles.

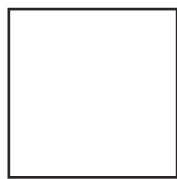

square

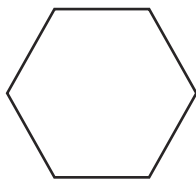

regular hexagon

Irregular polygons do not have equal sides and angles. They may have equal angles or equal sides but not both.

A rhombus has equal sides and a rectangle has equal angles but they are not regular (unless they are a square).

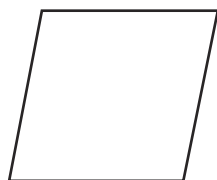

rhombus



rectangle

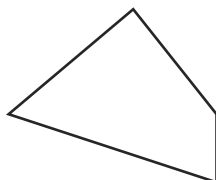

irregular quadrilateral

Angles in other regular polygons are:

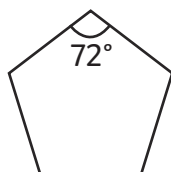

pentagon

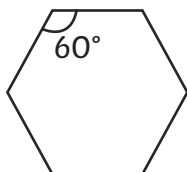

hexagon

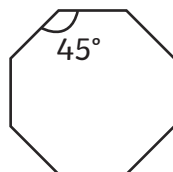

octagon

Circles

The main parts of a circle are:

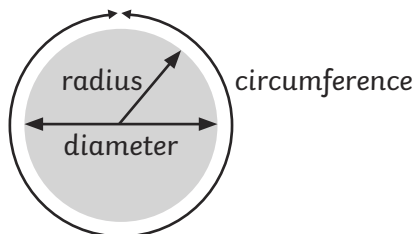

The circumference is the distance around the perimeter of the circle.

The radius is the distance from the centre to the circumference.

The diameter is the distance from the circumference to the circumference on the other side through the centre of the circle.

The diameter is double the radius.

Geometry – Position and Direction

Coordinates

Coordinates in all four quadrants.

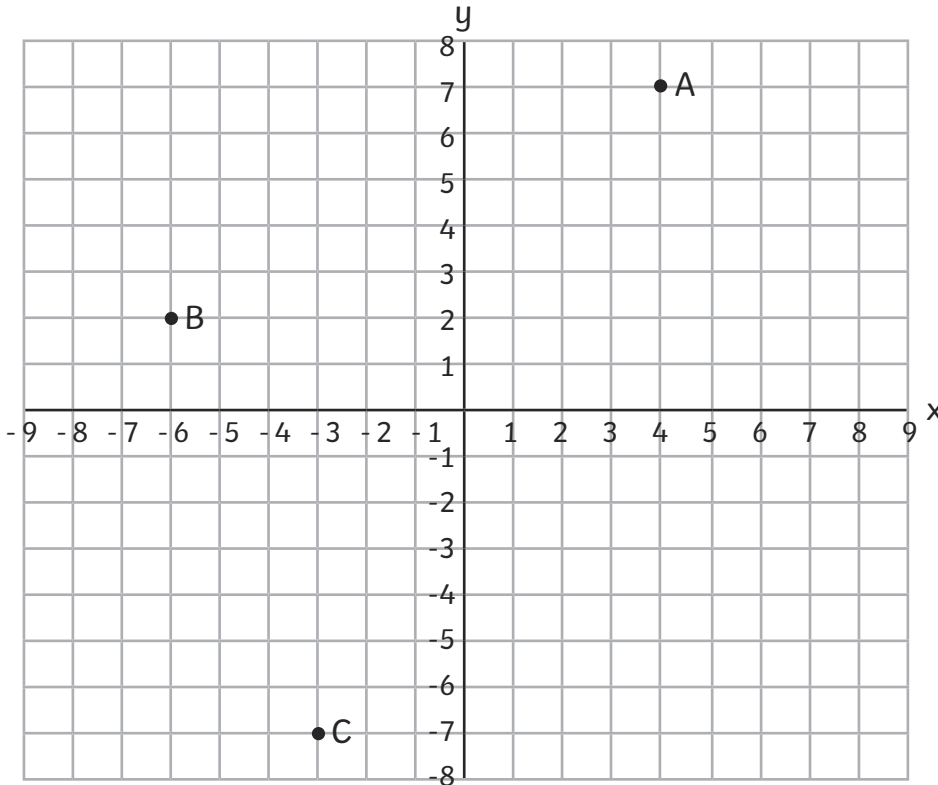

The coordinates are:

A (4, 7),

B (-6, 2)

C (-3, -7)

Some coordinates grids are drawn without squares.

Work out the coordinates of points a and b.

Compare the coordinates of the 2 triangles to find the answer.

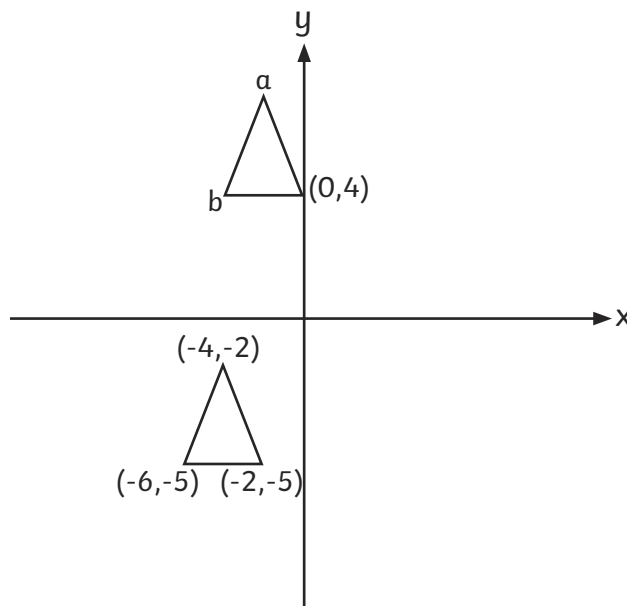

a = (-2, 7)

b = (-4, 4)

* not to scale

Translation

Translate shapes on a coordinates grid.

Translate this triangle so point A translates to point B.

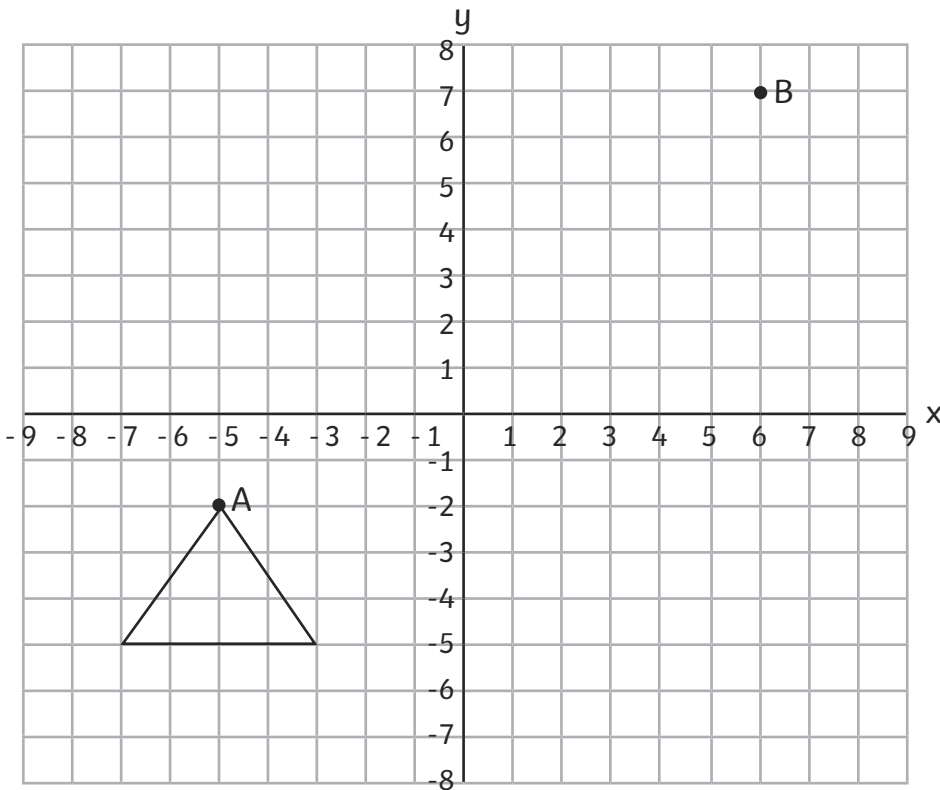

Translations can also be on blank grids as in the coordinates section above.

Reflection

Reflect shapes on a coordinates grid.

Reflect this triangle about the y-axis.

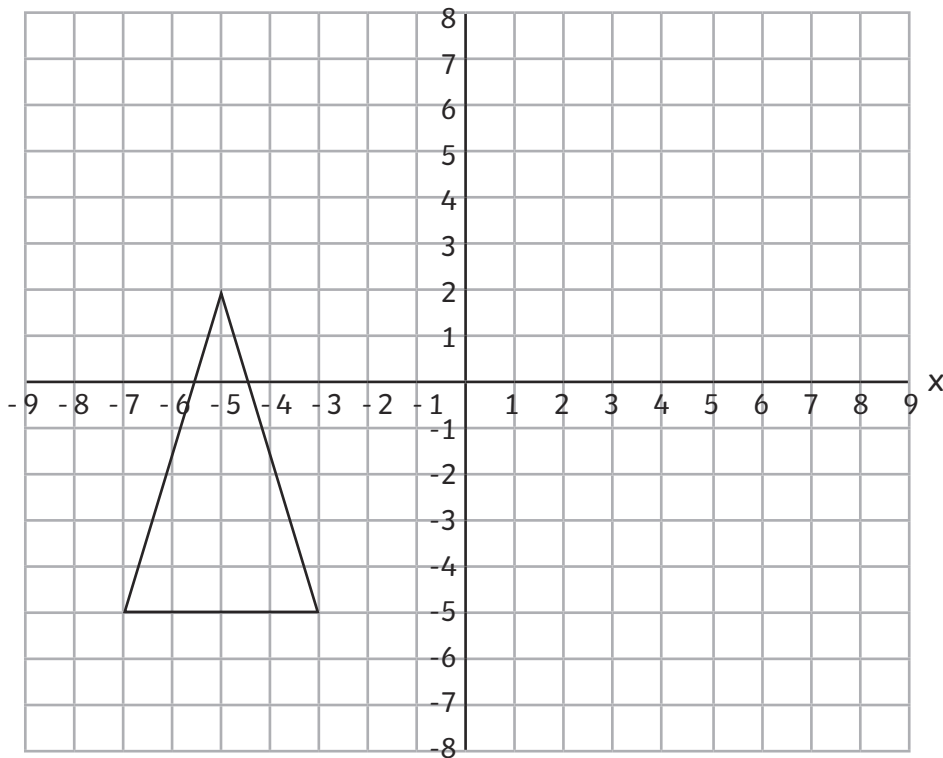

Reflections can also be on blank grids as in the coordinates section above.

Statistics

Present data in these graphs and tables and solve problems:

Pictograms

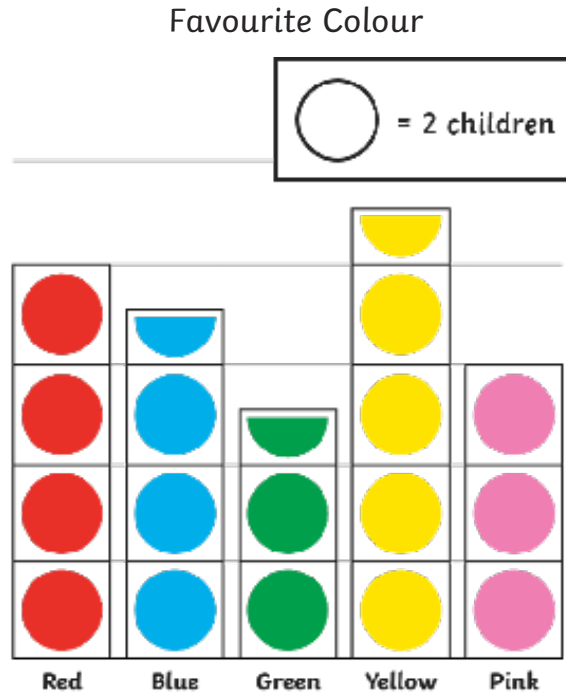

How many children chose their favourite colour? **35**

Bar Charts

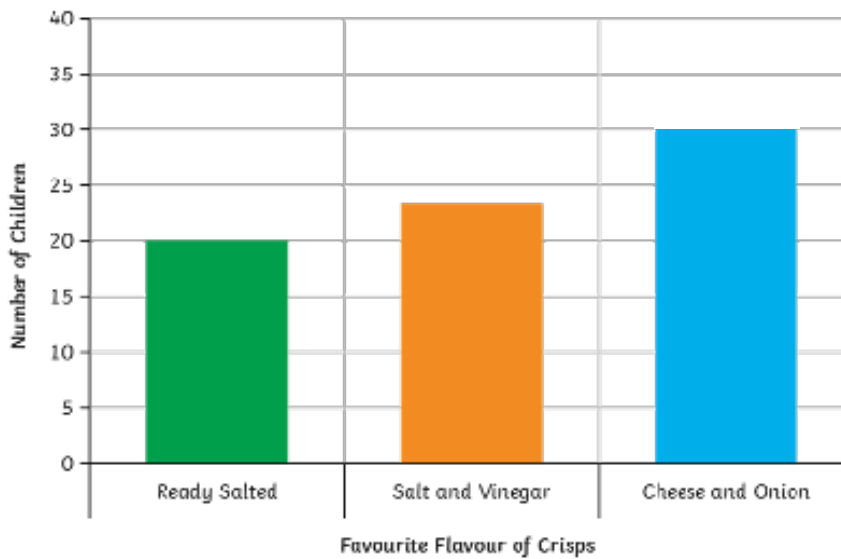

How many more children chose cheese and onion as their favourite crisps than ready salted?
10

Continuous data can have any value – usually a measurement.

The Height of Children

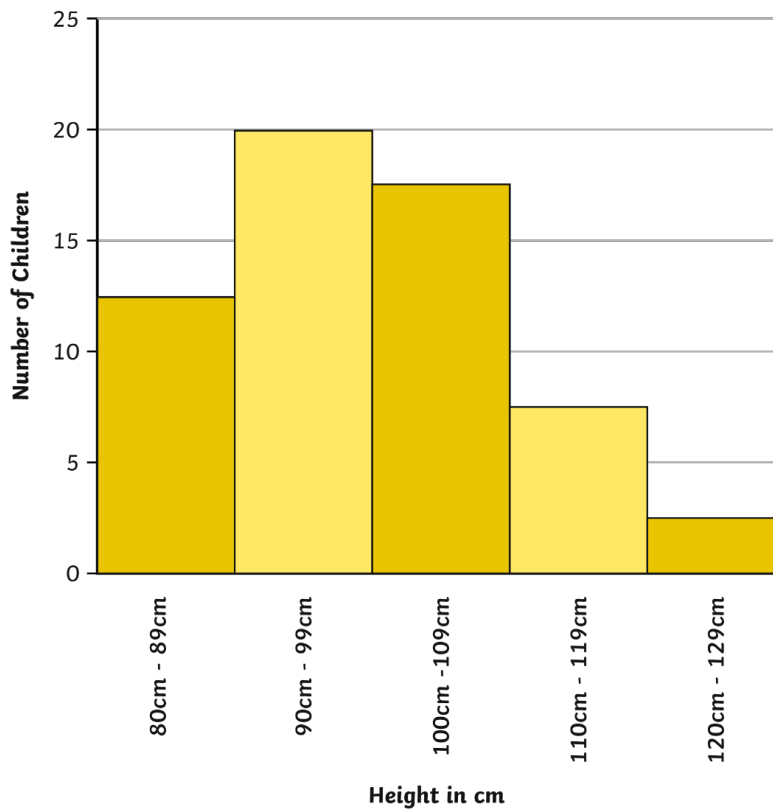

How many children are shorter than 1m? (Add the first 2 bars)

Tables

Here is a table of the chocolate bars sold to customers in a shop over 4 days.

	Monday	Tuesday	Wednesday	Thursday
Saturn	2	1	3	4
Twin	0	2	2	3
Stars	5	3	2	0
Cluster	2	2	2	2
Treasure	1	3	5	0
Tiger	6	3	4	1
Plimmy	1	3	2	2

Which chocolate bar is the most popular? **Tiger**

Time Graphs

Time graphs show the changing of data over time. These often take the form of line graphs but can also be a bar chart.

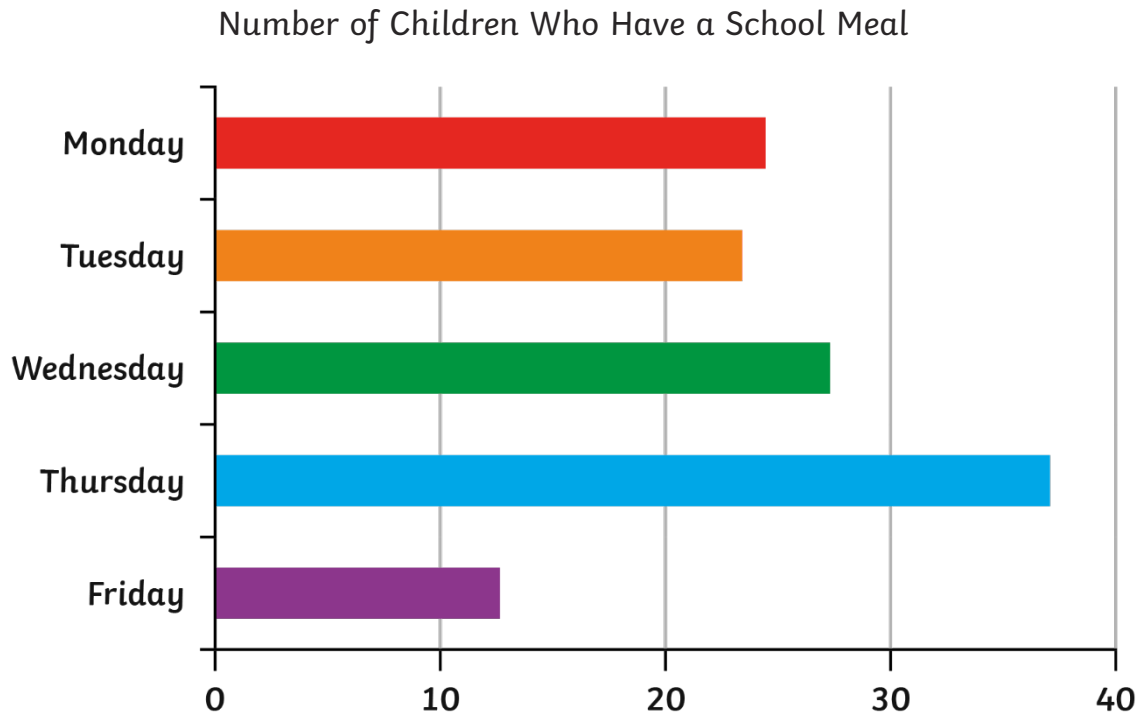

How many school meals were served during the week?

Line Graphs

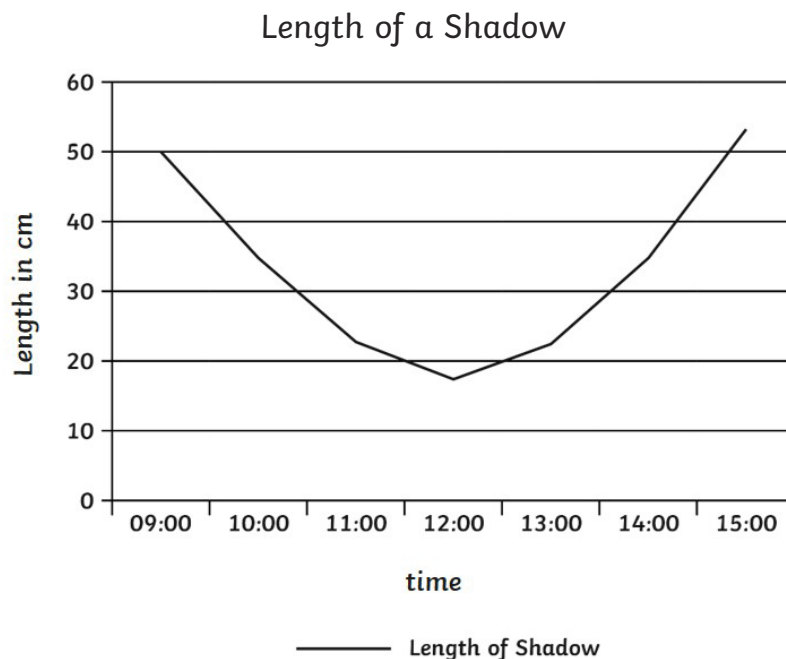

In which hour was the largest change in the length of the shadow?

Timetables

Train timetable from London to Newcastle



Destination	Journey A	Journey B	Journey C
London	10:20	11:30	16:40
Derby	12:20		18:00
Sheffield	12:40	13:10	18:30
Hull	13:20	13:55	19:15
Newcastle	14:25	14:40	

Which train takes the least time to get from London to Hull?

Pie Charts

Pie charts show data by dividing a circle to represent the different proportions of the data.

A class of children chose their favourite flavour of crisps. Here is a pie chart of the results.

-  Salt and Vinegar
-  Cheese and Onion
-  Ready Salted

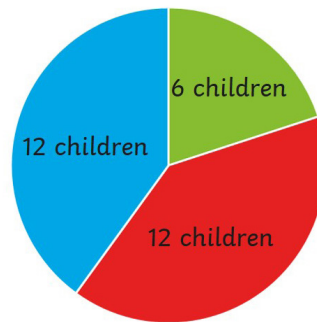

In questions about pie charts children have to use the proportion of the pie to work out answers.

In this pie chart, 20 children are asked how they travel to school.

Estimate how many children travelled by bus.

25% of the children travelled by bus and bicycle, which is 5 children. Estimate that bicycle represents 1 child and bus represents 4.

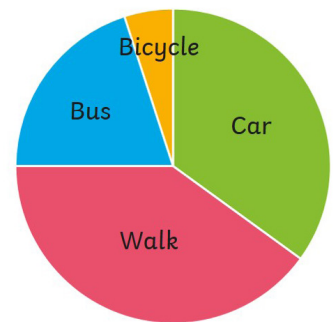

Mean

The mean of a set of data is equivalent to sharing the data out equally.

If 4 test scores are 3, 5, 6, 8, the mean is found by adding the data ($3 + 5 + 6 + 8 = 22$) and then sharing between the 4 scores by dividing by 4 ($22 \div 4 = 5.5$).

What is the mean of 15, 17, 20, 24, 24?

Important Vocabulary

This list is not exhaustive. Some vocabulary is described above.

Vocabulary	Meaning
2D shapes	Flat shapes with no thickness. In theory a 2D shape cannot be picked up, but in practice shapes made of paper are counted as 2D. (A list of shapes is included in the section on shape.)
3D shapes	A shape with 3 dimensions that can be picked up. (A list of shapes is included in the section on shape.)
Algebra	Letters or symbols used in the place of numbers.
Analogue	A clock face with hands.
Area	The amount of space taken up by a shape.
Calculation	The working out of an answer using addition, subtraction, multiplication or division.
Capacity	How much a container holds.
Commutativity	The answer is the same no matter which way the calculation is completed: e.g. $2 + 4 = 4 + 2$ or $2 \times 4 = 4 \times 2$.
Composite Number	A number that has more than 2 factors. (1 is not a composite number because it only has 1 factor.)
Cube number	The result of multiplying a whole number by itself twice: e.g. $2 \times 2 \times 2 = 8$
Denominator	The bottom part of a fraction.
Digit	A single symbol used to make a numeral: 7 (All numbers are made from the ten digits 0, 1, 2, 3, 4, 5, 6, 7, 8, 9, 0.)
Digital	A clock using digits to tell the time.
Discrete	A whole number of a set of objects.
Equation	A statement where the value of each mathematical expression is equal: e.g. $3 + 4 = 7$
Equivalent fraction	A fraction which has the same value but is divided into a different number of parts: e.g. $\frac{1}{2} = \frac{2}{4}$
Factor	A factor of a number is a number into which the number can be divided with no remainders: e.g. the factors of 8 are 1, 2, 4, and 8.
Factor pairs	Factor pairs are 2 factors that are multiplied together to make the number: e.g. the factor pairs of 8 are 1 and 8, 2 and 4.
Fraction	A number expressed as the number of parts into which the whole has been divided: e.g. $\frac{3}{4}$ represents 3 parts out of 4.

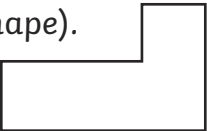
Improper fraction	A fraction where the numerator is larger than the denominator: e.g. $\frac{9}{2}$
Integer	A whole number with no parts: e.g. 5, 18, 109. A whole number with no fraction or decimal part: e.g. 6 or 57.
Inverse	An inverse operation is the opposite or reverse of an operation: e.g. the inverse of $6 - 4 = 2$ is $2 + 4 = 6$ or the inverse of $6 \div 3 = 2$ is $2 \times 3 = 6$.
Mass	Often known as weight – how much matter is in an object.
Mixed number	A whole number and a proper fraction: e.g. $4\frac{1}{2}$
Numeral	A symbol, symbols, word or words that stand for a number: 37 or thirty-seven.
Numerator	The top part of a fraction.
Perimeter	The measurement around an object.
Place value	The value of each digit in any number: In 27 the 2 represents 2 tens.
Polygon	A 2D shape with any number of sides.
Prime factor	A factor which is a prime number: e.g. 3 is a prime factor of 12.
Prime Number	A number that only has 2 factors: 1 and itself. (1 is not a prime number because it only has 1 factor.)
Proper fraction	A fraction where the numerator is smaller than the denominator: e.g. $\frac{1}{2}$
Quadrant	A quarter of the space represented by coordinates, bordered by the x and y axes.
Quadrilateral	Any four sided shape.
Rectilinear	A shape with all angles as right angles (the right angle can be inside or outside the shape). 
Scale	The mathematical relationship between different measurements or number of objects.
Square number	The result of multiplying a whole number by itself: e.g. $2 \times 2 = 4$
The Distributive Law	Multiplying 2 numbers by a number and adding, gives the same answer as multiplying the sum of the 2 numbers by the other number: e.g. $4 \times (3 + 2) = 4 \times 3 + 4 \times 2$.
Translation	The movement of a shape without rotation or reflection.
Volume	The amount of space taken up by an object.
Weight	Mass is measured by how much something weighs, but this can change in different locations.